

N8-E

Technical Drawing

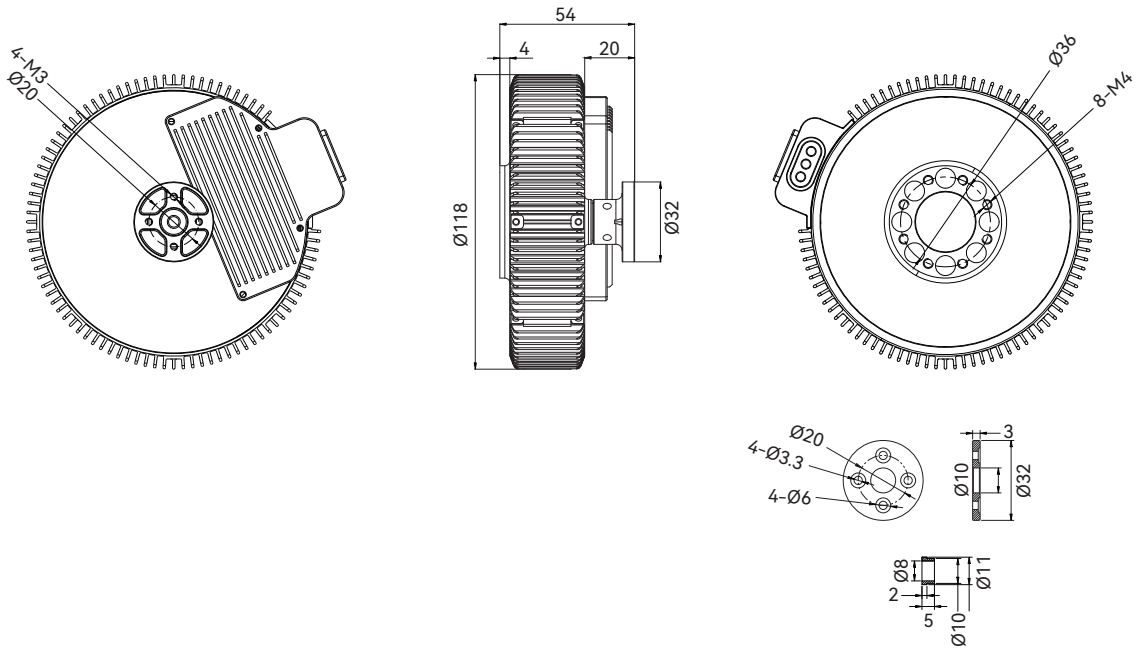

Specification

Model No.	N8-E KV110
Setup	N8-E-N60A+G30 Propeller
Recommended Battery	12S (LiPo)
Continuous Power	766W
Max Thrust	14kg
Wire Material, Wire Gauge, Color	Power Wires: 14#Silicone Wire-Red/Black Signal Wires: 5P PTFE Wire
Wire length	710±10mm
Weight (Incl. Cable)	745g±2% (Excluding Propeller)
IP	IP66
Recommended Ambient Temperature	-20°C~50°C

Motor Specs

Model No.	N8-E KV110
Motor Size (mm)	129.3*118*54mm
Configuration	36N42P
Shaft Diameter (mm)	IN10
Bearing	Imported 6900/Imported 6802
Magnet Level	180°C
Copper Wire	220°C
Coil Insulation Test	500V/5s
Rotor Dynamic Balance Standard	≤15mg

N8-E

ESC Specs	
Model No.	N60A
Protocol	TTL
Propeller-Locking	/
Continuous Current (A)	30 (Under Certain Heat Dissipation Conditions)
Standby Consumption (mA)	≤50
Throttle Refresh Frequency (Hz)	50~500
Output Cable (mm)	Silicone Wire-Black-16AWG-800±10
Encoder Cables (mm)	/
Throttle Pos. Range (us)	1100~1940
Control	PWM
Max Voltage (V)	48
Peak Current (A/10s)	60 (Under Certain Heat Dissipation Conditions)
Throttle Response Speed (ms)	300
Input Cable (mm)	Silicone Wire-Red/Black-14AWG-800±10
Signal Cable (mm)	Shielded Cables-Black-5C-800±10-JP-3P*2
Weight (Excl. Cable)	91±5