

# N8 L

## Technical Drawing

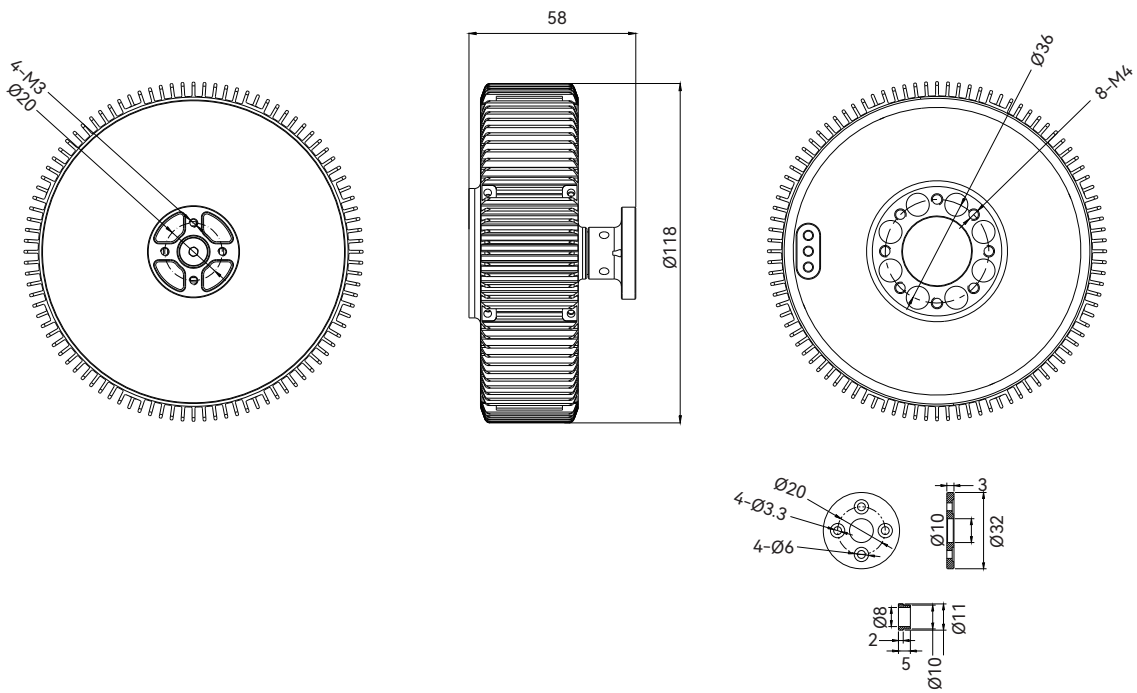

### Specification

Model No.	N8 L KV120
Motor Size (mm)	Ø118*58mm
Configuration	36N42P
Shaft Diameter (mm)	IN10
Bearing	Imported 6900/Imported 6802
Package Size	186*146*86mm
Magnet Level	180°C
Lead Cable (mm)	Enameled Wire 80mm
Copper Wire	220°C
Coil Insulation Test	500V/5s
Rotor Dynamic Balance Standard	≤15mg
IP	IP66

### Motor Specs

Model No.	N8 L KV120
Recommended Battery	12S (LiPo)
Internal Resistance (mΩ/25°C)	36mΩ
Continuous Power (180s)	802W
Max Thrust	17.5kg
KV (RPM/V)	KV120
Idle Current (A/15V)	1.8A
Peak Current (A)	80A
Recommended Ambient Temperature	-20°C~50°C
Weight (Incl. Cable)	695g±2%